

Think Outside. Inside.

user guide

welcome

■
■
■
Congratulations on your new ecobox.

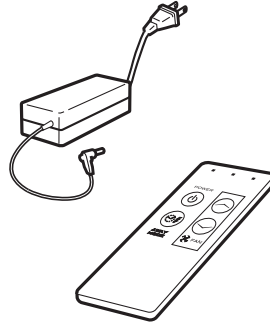
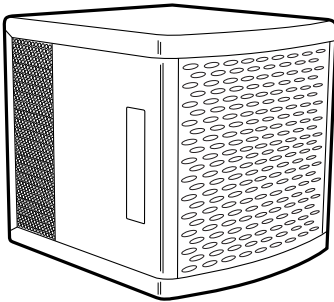

Your ecobox comes with a detachable power cord (US71059) and remote control (US71058).

EcoQuest Business Owner Name

Phone Number

introduction

Meet your ecobox!

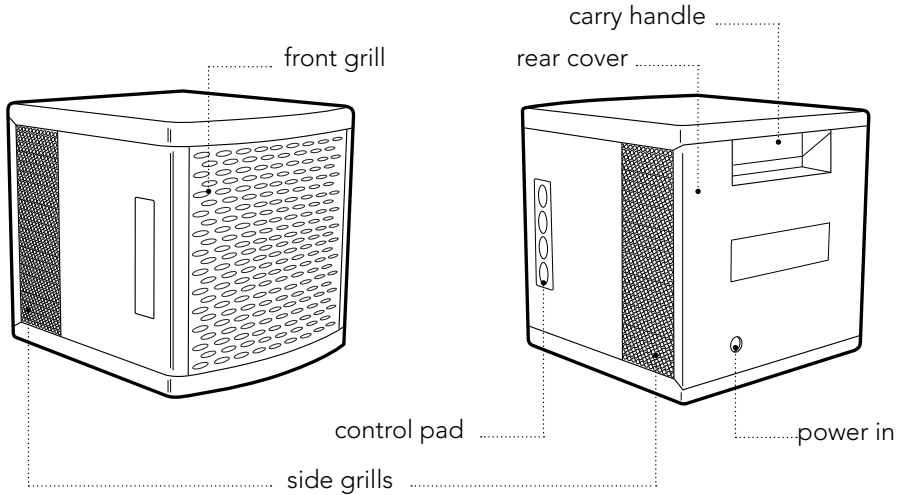

up to 1,500 square feet of coverage
6.5" high x 6.5" wide x 7" deep ■ weighs 2 pounds

placement

Where to put your ecobox

For best results, place your ecobox as high up as possible, with at least 2 inches of clearance on either side. You can also place your ecobox in trouble areas for extra effectiveness.

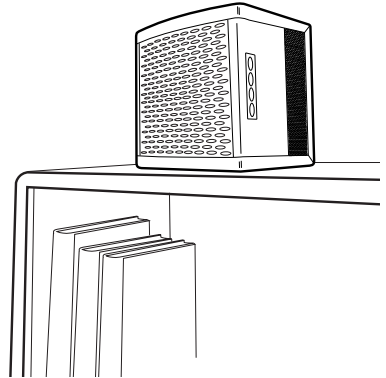

caution

Do not operate ecobox near heat sources, open flame, or combustible vapors or gases.

power supply

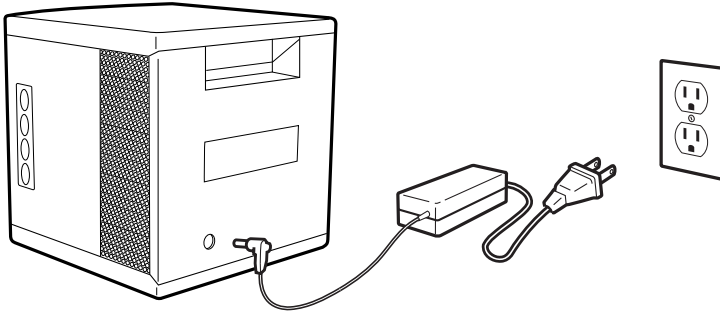

Plug power supply into the back of the ecobox and into a standard wall outlet.

15 volts DC ■ 20 watts power consumption
30 watts power consumption (away mode) ■ 3-speed fan

led information

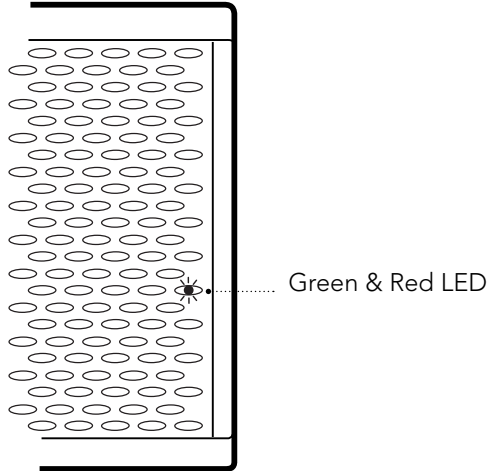

- Green LED solid = normal mode
- Green LED blinking = bulb absence/failure
- Green LED flash = remote or keypad command received
- Red LED solid = away mode (returns to normal mode after 2 hrs or user input is detected, whichever comes first)
- Red LED blinking = supply voltage is greater than 18VDC or less than 12VDC

control pad

Operating your ecobox.

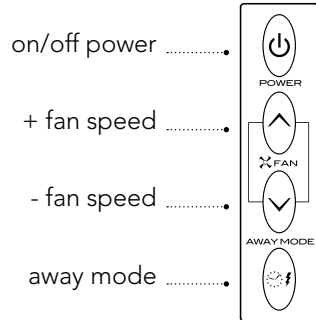
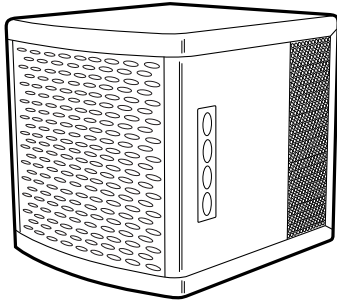

The control pad is conveniently located on the right side of your ecobox.

! caution

Away Mode is intended for unoccupied spaces only. Please be sure all people and pets have vacated the area when Away Mode is in use.

remote control



on/off power

away mode

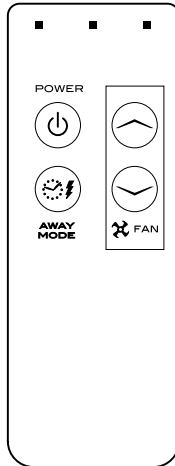

..... + fan speed

..... - fan speed

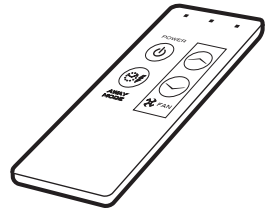

The ecobox remote control gives you the convenience of control from anywhere in the room. Before use, remove paper tab from the bottom of the remote. When replacing battery, choose a 3 Volt lithium cell CR2025.

parts

Replacement parts.

side grills
US71070

purifier plate
US71061

remote control
US71058

ActivePure (RCI) cell
US71060

power cord
US71059

optional car adapter
US71078

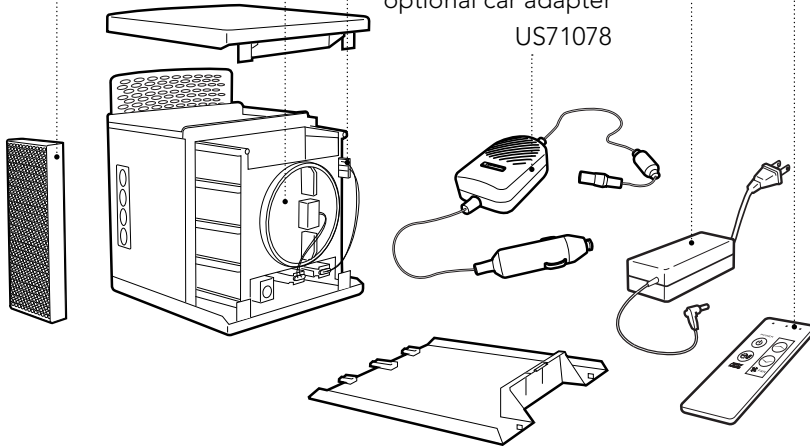

If your unit fails to operate properly or you have questions, contact your EcoQuest Business Owner for further assistance. Contact EcoQuest at:
EcoQuest International, 310 T. Elmer Cox Drive, Greeneville, TN 37743
800.989.2299 or visit www.EcoQuest.com for additional support.

maintenance

Caring for your ecobox.

	every month	every year	every 3 years	part numbers
clean front grill	●			
clean side grills	●			
clean purifier plate	●			
replace ActivePure (RCI) cell		●		US71060
replace purifier plate			●	US71061

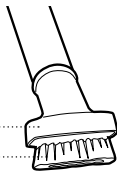
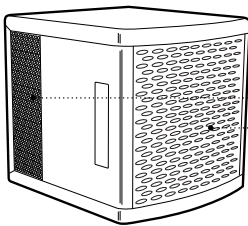

upkeep

Periodically vacuum the grills or wipe the front grill with a soft towel. You can wash the two side grills in warm water and let dry completely before reinstalling (replace if necessary). Wipe down the outside with a damp (not wet) cloth. Reassemble when finished.

10 ! caution

Always unplug the power cord from the back of your ecobox before servicing. Removing cover may expose ultraviolet light source. To protect against eye damage, always unplug before servicing.

repair and upkeep

How to change the cell.

Note: To remove back panel, press latch and pull back.

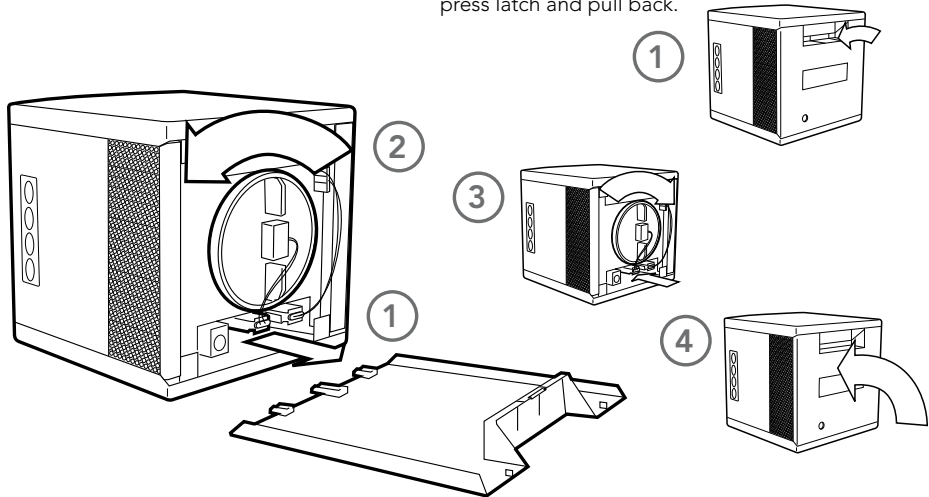

Remove the back panel and unplug the power connector to the ActivePure (RCI) cell. Turn the ActivePure (RCI) cell counterclockwise and remove. Reverse order to replace cell.

! caution

Always unplug the power cord from the back of your ecobox before servicing. Removing cover may expose ultraviolet light source. To protect against eye damage, always unplug before servicing.

repair and upkeep

How to change the plate.

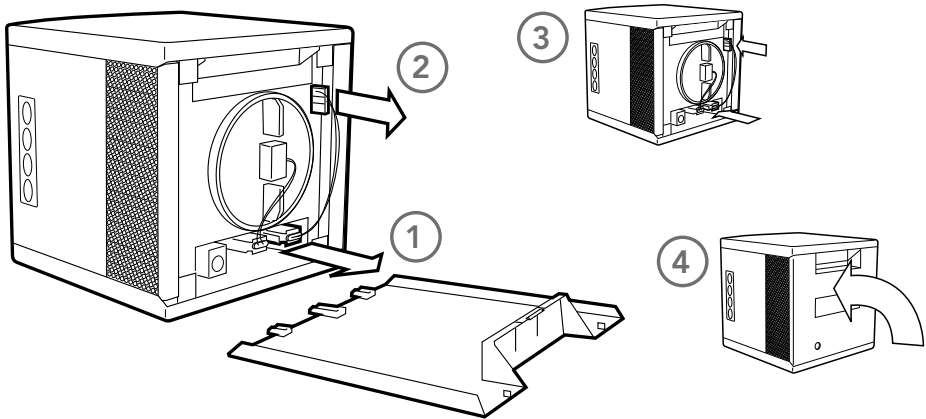

Remove the back panel and unplug the power connector to the purification plate. Remove the purification plate from its slot. Reverse order to replace plate.



caution

Always unplug the power cord from the back of your ecobox before servicing. Removing cover may expose ultraviolet light source. To protect against eye damage, always unplug before servicing.

repair and upkeep

How to clean the purification plate.

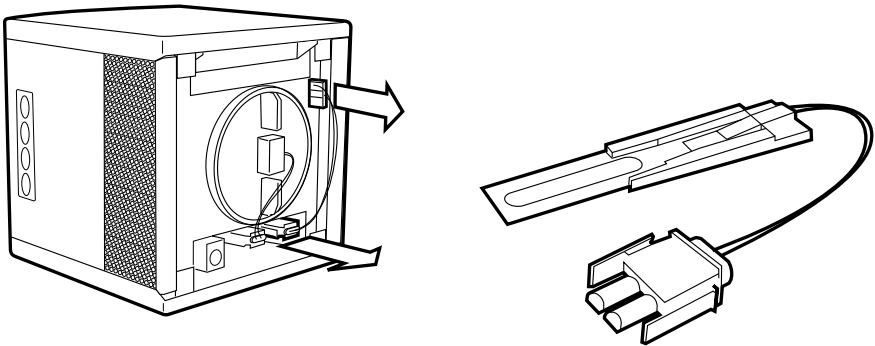

Remove the purification plate from its slot. Clean plate by wiping with a cotton swab dipped in denatured alcohol. Allow plate to dry completely before reinstalling.

! caution

Always unplug the power cord from the back of your ecobox before servicing. Removing cover may expose ultraviolet light source. To protect against eye damage, always unplug before servicing.

deep cleaning

How to disassemble your ecobox for cleaning.

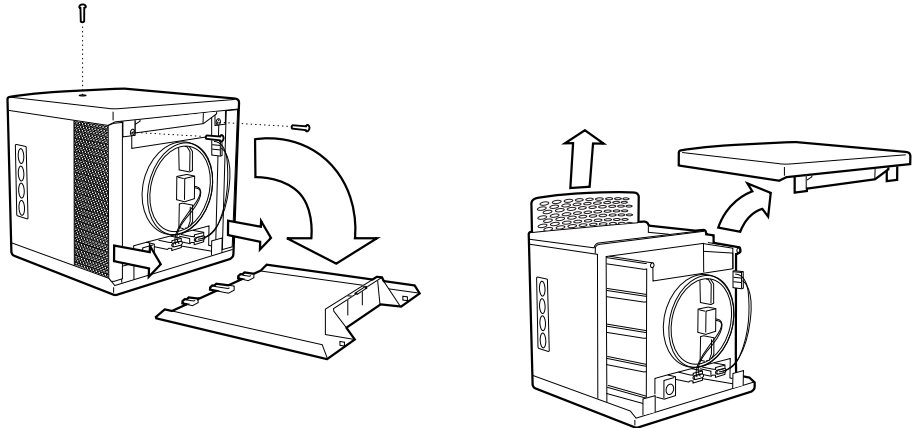

Slide out the side grills. Remove the 2 screws behind the back panel and the one on top. The top will pull away and front grill will slide up and out. Now you can completely clean the fan and the inside of your ecobox.

14 **!** **caution**

Always unplug the power cord from the back of your ecobox before servicing. Removing cover may expose ultraviolet light source. To protect against eye damage, always unplug before servicing.

fcc declaration of conformity

Name: EcoQuest International

Model: ecobox

This device complies with
Part 18 of the FCC Rules.

RESPONSIBLE PARTY



ECOQUEST INTERNATIONAL

EcoQuest International
310 T. Elmer Cox Drive
Greeneville, TN 37743

Ph: (800) 989-2299

Signature: 

Printed Name: David Blackwell

Title: Engineering Manager

Date: 12/20/06

This equipment has been tested and found to comply with the limits for Industrial, Scientific, and Medical Equipment (ISM), pursuant to Part 18 of the FCC Rules. These limits are designed to provide reasonable protection against harmful interference in a residential installation. This equipment generates, uses, and can radiate radio frequency energy, and if not installed and used in accordance with the instructions, may cause harmful interference to radio communications. However, there is no guarantee that interference will not occur in a particular installation. If this equipment does cause harmful interference to radio or television, which can be determined by turning the equipment off and on, the user is encouraged to try to correct the interference by one or more of the following measures:

Reorient or relocate the receiving antenna.

Increase the separation between the equipment and receiver.

Connect the equipment into an outlet on a circuit different from that to which the receiver is connected.

Consult the Distributor or an experienced radio/TV technician for help.



printed on recycled paper



ECOQUEST INTERNATIONAL

800.989.2299 ■ 310 t. elmer cox dr. ■ greenville, tn 37743
www.ThinkOutsideInside.com

